

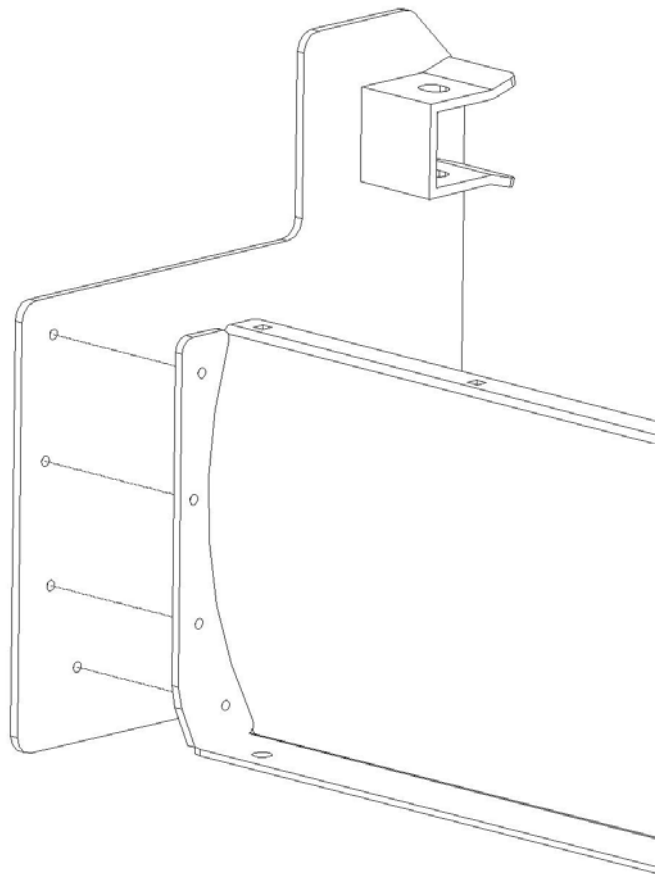

BXS4860 – Box Scraper Ends

No	Part Name	Description	Qty
1	Left hand end plate assembly		1
2	Right hand end plate assembly		1
3	Bolt	5/16" x 1"	8
4	Nylock Nut	5/16"	8
5	Flat Washer	5/16"	8
6	Bent Hitch Pin	5/8" x 3"	2
7	"R" Pin - Keeper	Φ3mm	2



Assembly Instructions:

1. Secure #1 and #2 (End Plates) to Rear Blade Assembly with 5/6" Bolts, Washers and Nylock Nuts as shown in picture above.
2. Use (2) #6 (3" Bent Hitch Pins) to secure Rear Blade / Box Scraper assembly to Accessory Tool Bar, secure Rear Blade Pivot Assembly with 5/8" x 3" Bent Hitch Pin to Accessory Tool Bar also.

For additional assistance, please contact our customer service department at (877)-9KOLPIN or customerservice@kolpin.com.

Kolpin Powersports, Inc. - 205 N. Depot Street - Fox Lake, MN 53933
Phone (920) 928-3118 - Web: www.kolpinpowersports.com